

Description

The BP85256D is a high performance, highly integrated power supply switcher IC with low standby consumption. The BP85256D can be configured as buck, buck-boost topologies for universal 85~265V AC inputs.

The BP85256D integrates a 650 V power MOSFET, a high-voltage current source for self-biasing, a current sensing circuit, an output feedback circuit, a freewheeling diode and a controller. External VCC capacitor and loop compensation components can be eliminated, which reduces cost and size of overall power systems, and improves reliability.

The BP85256D employs multi-mode control algorithm. As a result, the no-load power consumption and the average efficiency have been improved, and the audible noise is reduced.

The BP85256D features comprehensive protections, including short circuit protection (SCP), output over voltage protection (OVP), over load protection (OLP), FB open loop protection, cycle-by-cycle current limit, and over temperature protection (OTP).

The BP85256D is available in SOP-7 package.

Features

- Integrated VCC capacitor, freewheeling diode and feedback diode
- Integrated 650V power MOSFET
- Integrated high-voltage current source for self-biasing
- No load consumption <50mW at 230VAC
- Fixed 12V output
- Fast transient response and low output ripple
- Optimized line and load regulation
- Reduced audible noise at light load
- Adaptive switching frequency, 45kHz maximum
- Frequency modulation for EMI improvement
- Internal soft start
- Comprehensive protections
 - Short circuit protection (SCP)
 - Over voltage protection (OVP)
 - Over load protection (OLP)
 - Open loop protection
 - Cycle-by-cycle current limit
 - Over temperature protection (OTP)

Applications

- Home appliances
- Motor driver standby power
- IoT, smart home, smart LED drivers

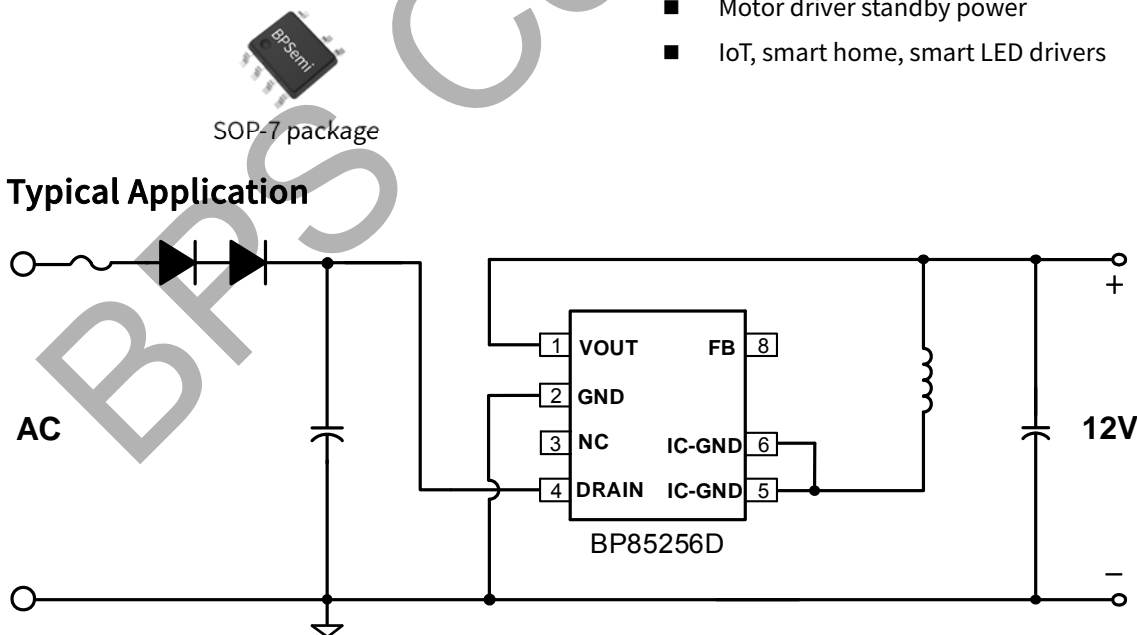

Figure 1. Typical buck application with the BP85256D

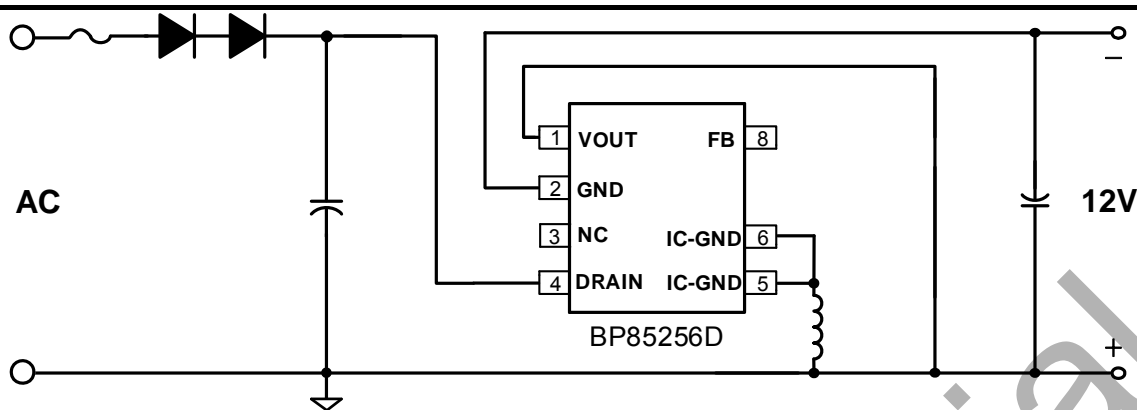
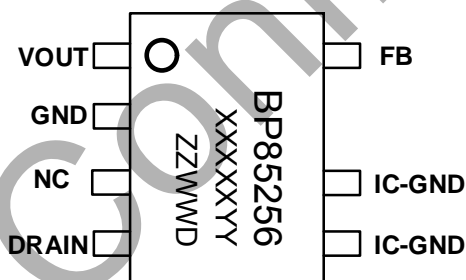

Figure 2. Typical buck-boost application with the BP85256D

Ordering Information

Part Number	Package	Packing	Marking
BP85256D	SOP-7	Tape & Reel 4,000 pcs/Reel	BP85256 XXXXXXYY ZZWWD

Pin Configuration and Marking Information



BP85256: Part number
XXXXXXYY: Lot code
ZZ: Internal code
WW: Week code
D: Package type(D:SOP)

Figure 3. SOP-7 pin configuration

Pin Functions

Pin NO.	Pin Name	Description
1	VOUT	Output voltage pin. Anode of the internal feedback diode.
2	GND	Ground reference for the output voltage. Anode of the internal freewheeling diode.
3	NC	Not connected.
4	DRAIN	Drain connection of the internal power MOSFET. Input of the high-voltage current source.
5、6	IC-GND	Ground reference for the IC. Source connection of the internal power MOSFET. Cathode of the internal freewheeling diode.
8	FB	Voltage feedback pin. Cathode of the internal feedback diode. No external connection required.

Disclaimer

The information provided in this datasheet is believed to be accurate and reliable. However, Bright Power Semiconductor (BPS) reserves the right to make changes at any time without prior notice.

No license, to any intellectual property right owned by BPS or any other third party, is granted under this document. BPS provides information in this datasheet “AS IS” and with all faults, and makes no warranty, express or implied, including but not limited to, the accuracy of the information provided in this datasheet, merchantability, fitness of a specific purpose, or non-infringement of intellectual property rights of BPS or any other third party. BPS disclaims any and all liabilities arising out of this datasheet or use of this datasheet, including without limitation consequential or incidental damages.

BPS Confidential