

BPA8505D

Integrated Energy Efficient Off-line Switcher IC

Description

The BPA8505D is a high performance, highly integrated power supply switcher IC with low standby consumption. The BPA8505D can be configured as buck, buck-boost, or flyback topologies for universal 85~265V AC inputs.

The BPA8505D integrates a 700 V power MOSFET, a high-voltage current source for self-biasing, a current sensing circuit, and an advanced controller. External loop compensation components can be mostly eliminated, which reduces cost and size of overall power systems, and meantime achieves high reliability.

The BPA8505D employs advanced multi-mode control algorithm. As a result, the no-load power consumption and average efficiency of the power systems have been improved and audible noise is reduced.

The BPA8505D features comprehensive protections, including short circuit protection (SCP), output over voltage protection (OVP), over load protection (OLP), cycle-by-cycle current limit, and over temperature protection (OTP).

The BPA8505D is available in SOP-7 packages.



SOP-7 package

Typical Application

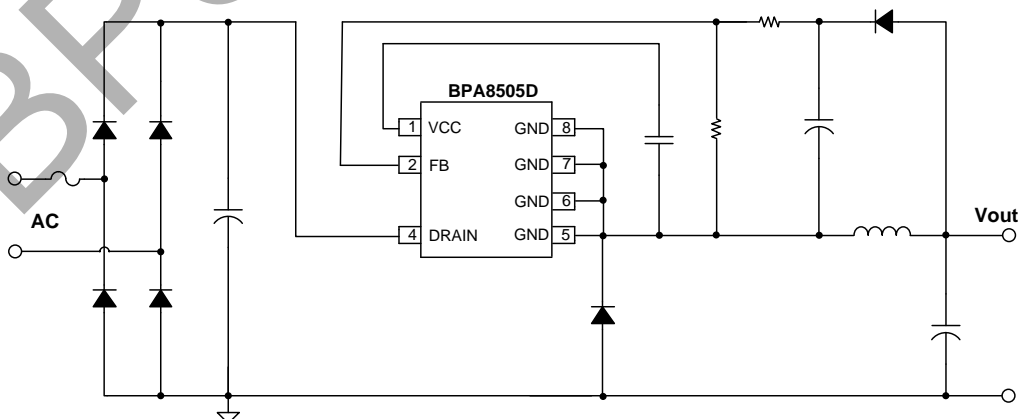

Figure 1. Typical buck application with the BPA8505D

Features

- Integrated 700V power MOSFET
- Integrated high-voltage current source for self-biasing
- <100mW no load consumption at 230VAC
- Excellent transient response
- Low output ripple
- Optimized line and load regulation
- Reduced audible noise at light load
- Adaptive switching frequency, 45kHz maximum
- Frequency modulation for EMI improvement
- Internal soft start
- Comprehensive protections
 - Short circuit protection (SCP)
 - Over voltage protection (OVP)
 - Over load protection (OLP)
 - Cycle-by-cycle current limit
 - Over temperature protection (OTP)

Applications

- Home appliances
- Motor driver standby power supply
- IoT, smart home, smart LED drivers
- Industrial controls

Ordering Information

| Part Number | Package | Packing | Marking |
|-------------|---------|-------------------------------|------------------------------|
| BPA8505D | SOP-7 | Tape & Reel 4,000 pcs/Reel | BPA8505 XXXXXXYY XXWWD |

Pin Configuration and Marking Information

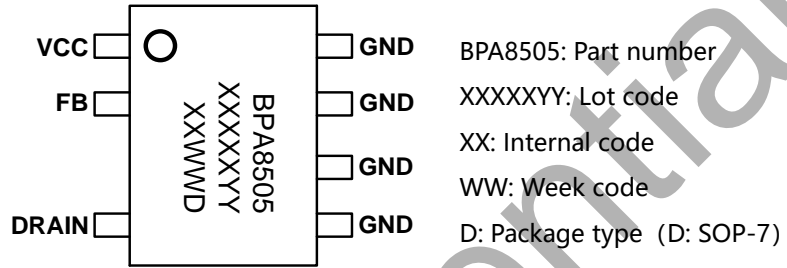

Figure 2. SOP-7 pin configuration

Pin Functions

| Pin NO. | Pin Name | Description |
|---------|----------|---|
| 1 | VCC | Power supply pin of the IC. A 0.1 μ F external bypass capacitor to GND is required on this pin. |
| 2 | FB | Output voltage feedback pin. Connect an external resistor divider to set the output voltage. |
| 4 | DRAIN | Drain connection of the internal power MOSFET. Input of the high-voltage current source. |
| 5、6、7、8 | GND | Ground reference for the VCC and FB pins. Source connection of the internal power MOSFET. |

Recommended Output Current (Buck topology) (Note 1)

| Part NO. | 230VAC \pm 15% | | 85 ~ 265VAC | |
|----------|------------------|-------|-------------|-------|
| | DCM | CCM | DCM | CCM |
| BPA8505D | 200mA | 300mA | 200mA | 300mA |

Note 1: The recommended output current is for the buck topology with adequate PCB heat sinking.

Disclaimer

The information provided in this datasheet is believed to be accurate and reliable. However, Bright Power Semiconductor (BPS) reserves the right to make changes at any time without prior notice.

No license, to any intellectual property right owned by BPS or any other third party, is granted under this document. BPS provides information in this datasheet "AS IS" and with all faults, and makes no warranty, express or implied, including but not limited to, the accuracy of the information provided in this datasheet, merchantability, fitness of a specific purpose, or non-infringement of intellectual property rights of BPS or any other third party. BPS disclaims any and all liabilities arising out of this datasheet or use of this datasheet, including without limitation consequential or incidental damages.

BPS Confidential